

DATASHEET

Weii

SRCW004 • ceriiANT®



Features

- 2.4GHz applications
- Bluetooth®, Wi-Fi®, Zigbee®, ISM.
- Ultra-small ceramic chip solution.
- High Efficiency.
- SMD mounted.
- Resistant to de-tuning.
- Omni-directional
- RoHS compliant

Note: This product is compatible with Bluetooth® technology but does not incorporate Bluetooth® technology

1. Description

For use in all 2.4GHz applications. Compact design with simple integration and implementation. Effective on varying GND plane sizes. Coexists well in multiple antenna systems. Resistant to de-tuning effects means devices can work well in different environments. Ideal antenna choice for small wearable devices.

2. Applications

- Small wearable devices
- Headsets
- Medical devices
- PNDs
- Dongles
- Sensors

3. General data

Frequency	2.4-2.5GHz
Polarization	Linear
Operating temperature	-40°C to 125°C
Impedance with matching	50 Ω
Weight	<0.015g
Antenna type	SMD
Dimensions	1.0 x 0.5 x 0.5 (mm)

4. Part number

SRCW004



5. RF characteristics

Frequency	2.4-2.5 GHz
Peak gain	2.5 dBi
Average gain	-1.5 dBi
Average efficiency	70%
Maximum return loss	<-10 dB
Maximum VSWR	1.6:1

All data measured on Antenova's evaluation PCB Part No. SRCW004-EVB-1 (EVK size 60mm x 37mm)

6. RF performance

6.1. Return loss

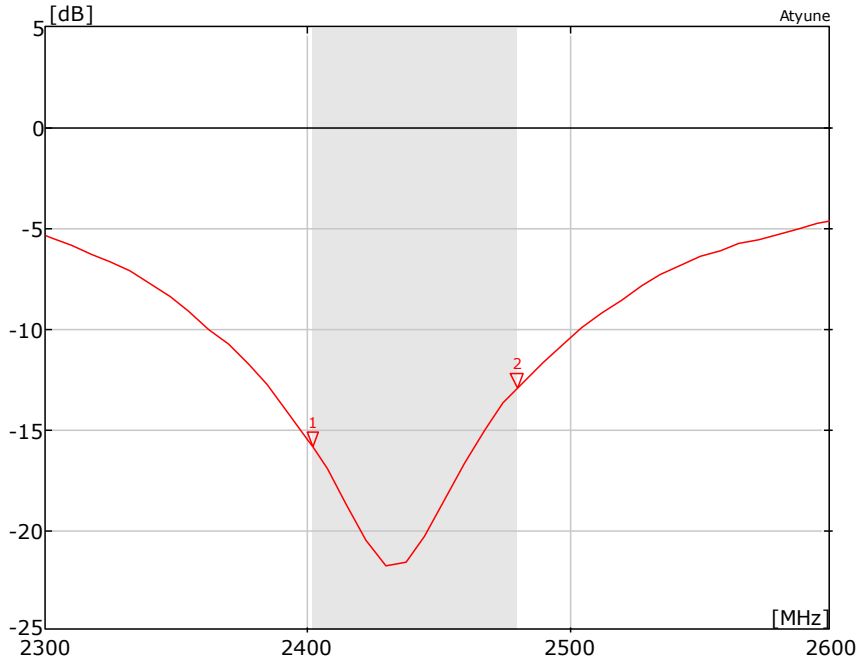

All data measured on Antenova's evaluation PCB Part No. SRCW004-EVB-1 (EVK size 60mm x 37mm)

6.2. VSWR

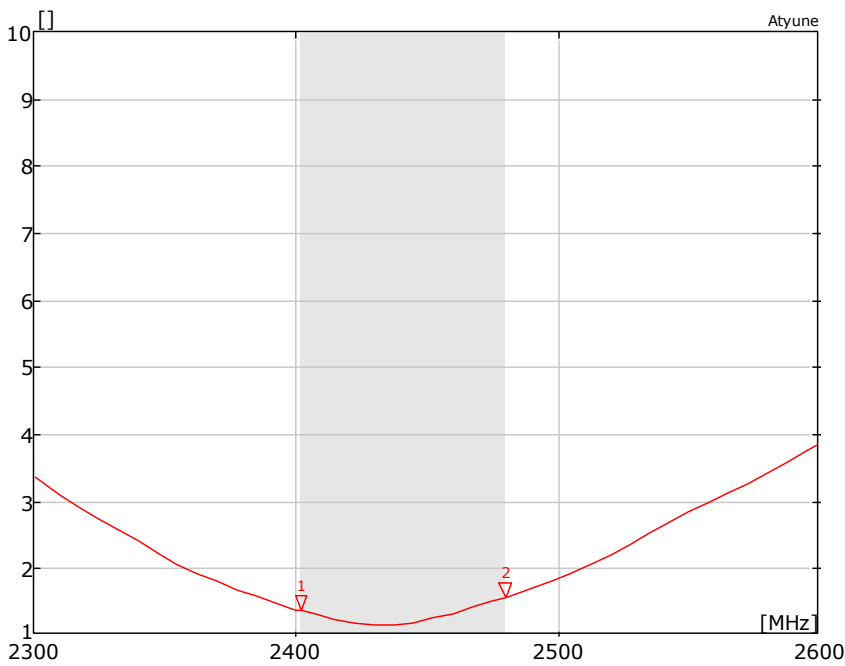

All data measured on Antenova's evaluation PCB Part No. SRCW004-EVB-1 (EVK size 60mm x 37mm)

6.3. Efficiency

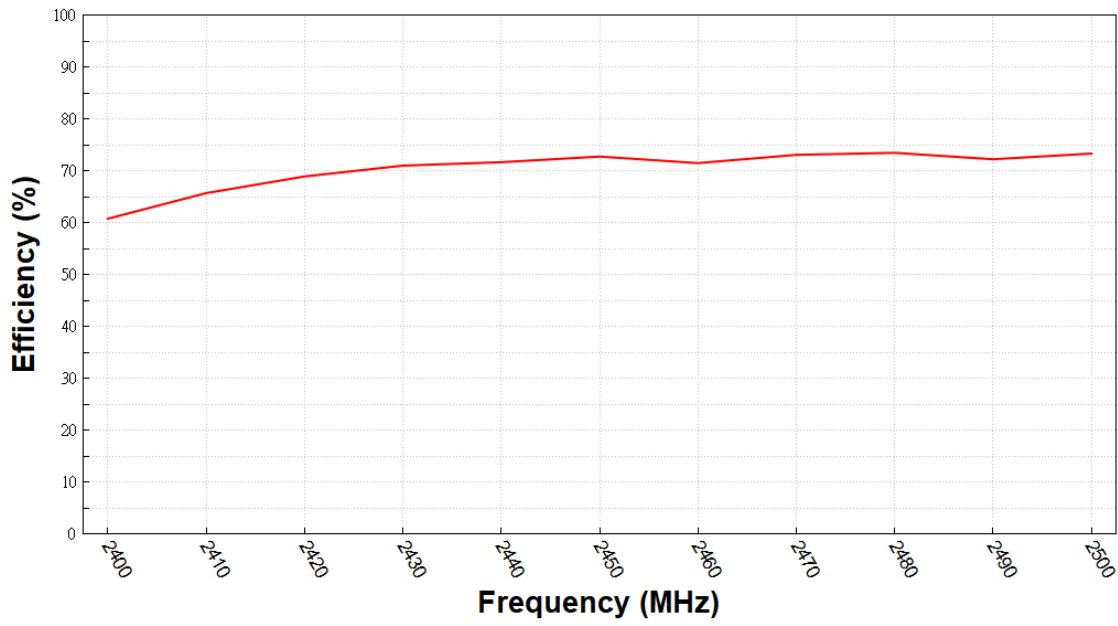

All data measured on Antenova's evaluation PCB Part No. SRCW004-EVB-1(EVK size 60mm x 37mm)

6.4. Antenna patterns

6.4.1. 2400 MHz – 2500 MHz

3D pattern at 2450MHz

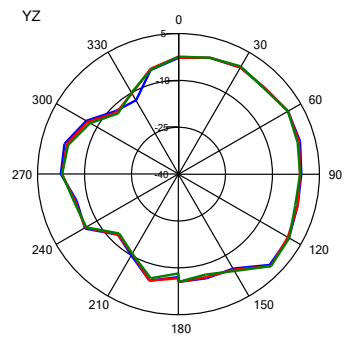
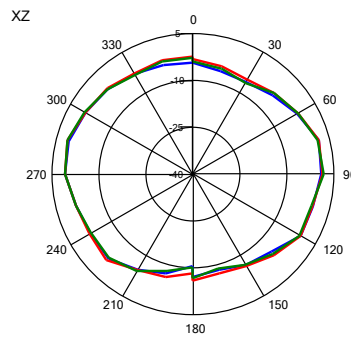
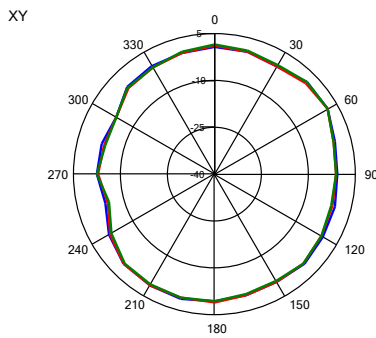
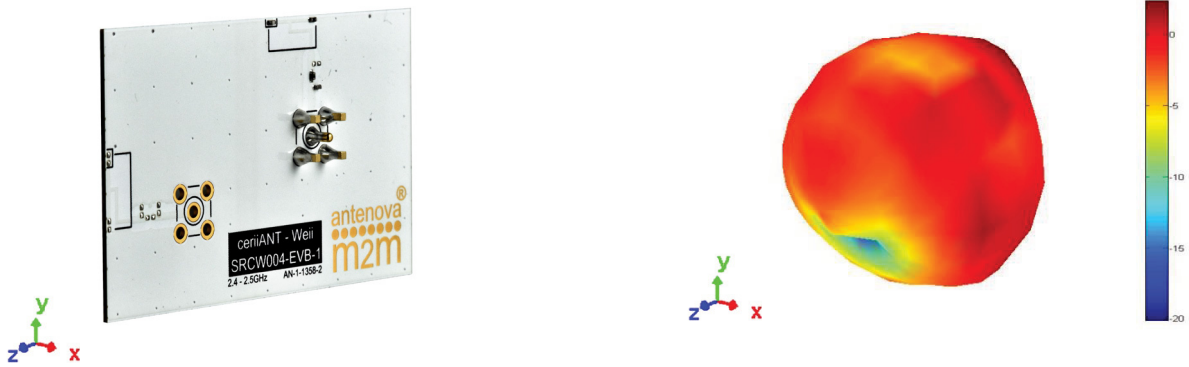

— 2.4GHz — 2.44GHz — 2.48GHz

7. Antenna dimensions

7.1. Antenna dimensions

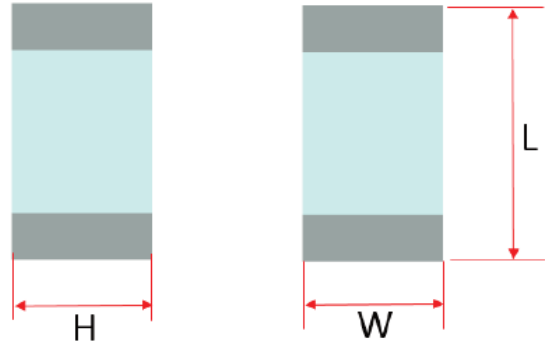

L	W	H
1.0 ±0.1	0.5 ±0.15	0.5 ±0.1

All dimensions in (mm)

8. Schematic

The circuit symbol for the antenna is shown below.

Name	Description
A1	SRCW004 Antenna
R1	Tuning Component (Default=OR Resistor)
Pinetwork	Antenna matching network

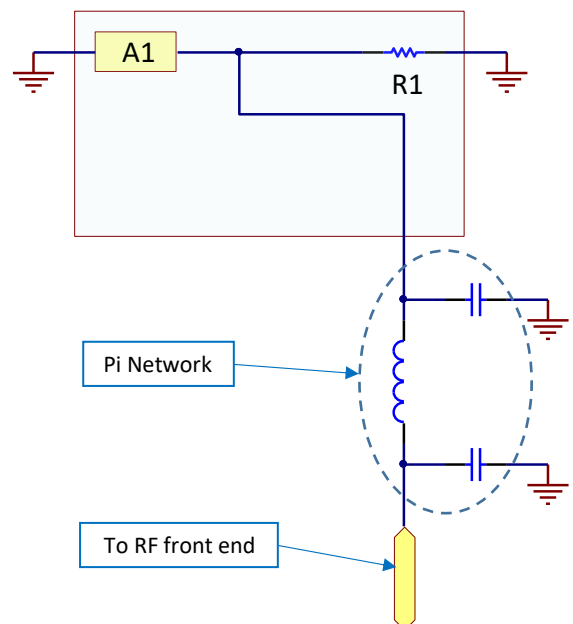

9. Host PCB footprint

The recommended host PCB footprint is below.

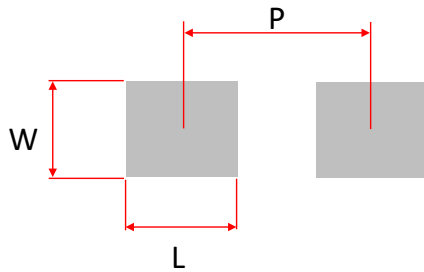

■ PCB copper pads

L	W	P
Length	Width	Pitch
0.6 ± 0.1	0.5 ± 0.15	1.0 ± 0.1

All dimensions in (mm)

10. Electrical interface

10.1. Transmission line

All transmission lines should be designed to have a characteristic impedance of 50Ω.

- The length of each transmission lines should be kept to a minimum
- All other parts of the RF system like transceivers, power amplifiers, etc, should also be designed to have a 50 Ω impedance

A co-planar transmission line can be designed using an online transmission line calculator tool, see TOOL at <https://www.antenova.com/>.

The PCB thickness, copper thickness and substrate dielectric constant are entered, then the tool calculates the transmission line width and gaps on either side of the track to give a 50 Ω impedance.

10.2. Matching circuit

The antenna requires a matching circuit that must be optimized for each product. The matching circuit will require up to three components (0402 size), and an additional tuning element is also required (0402 size) the following pad layout should be designed into the device so the correct circuit can be installed.

Note: The tuning component by default is a 0402 zero ohm resistor.

In addition to the matching circuit, a separate DC blocking capacitor will also be required between the radio and the antenna matching circuit.

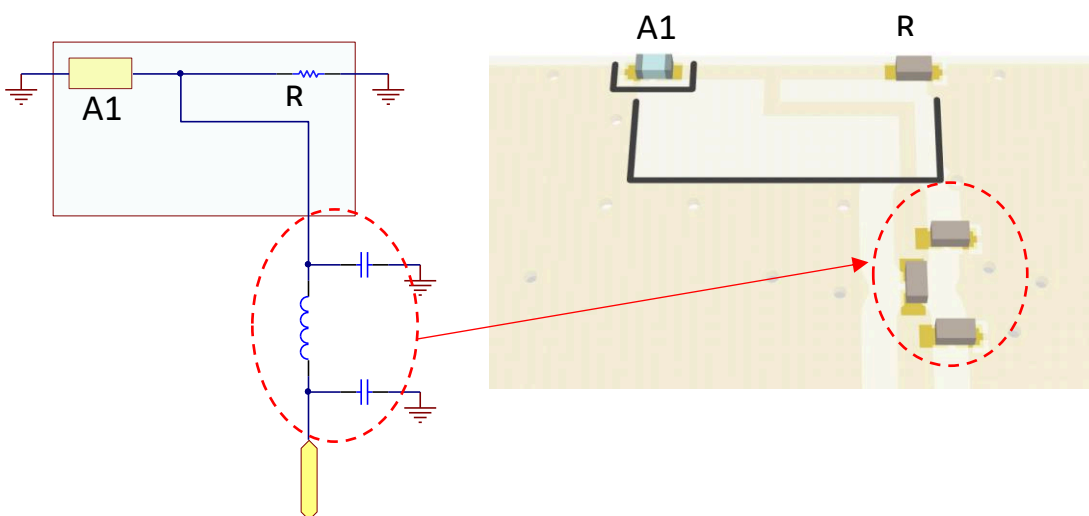

11. Antenna integration guide

We recommend the following during the design phase to maximise antenna performance and minimize noise:

- Minimum 4 layer PCB
- Route signals and power internally where possible
- Flood all layers with ground
- Knit ground on all layers together with plenty of vias

Follow placement guidance carefully. Antenova provide technical support to help you with your design, and also provide design assistance on PTCRB certification. Register for an account on <https://ask.antenova.com/> to access technical support.

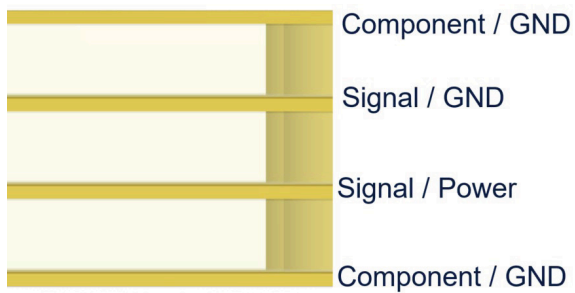

11.1. Antenna placement

The antenna should be placed in the best suited position to effectively radiate. Whichever the PCB size used, the most ideal position is along the longest edge of the PCB at the centre of that edge.

The Antenova placement tool can be used to advise on antenna placement, see TOOL at <https://www.antenova.com/>.

Antenna placed equal distance from either side



Where the centre is not a viable option the antenna can be placed offset on the PCB to within the limits shown below.

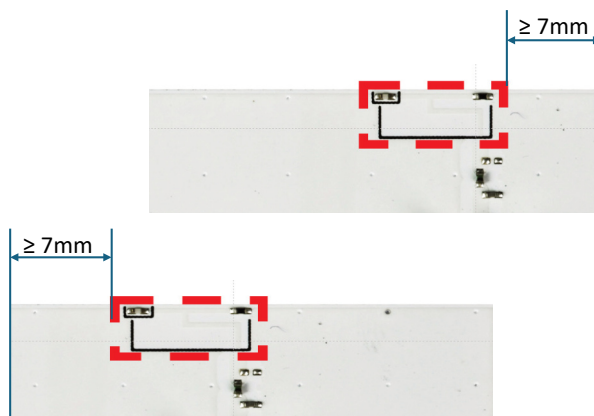

Minimum recommended host PCB size

The recommended minimum PCB size for the antenna is defined by the PCB edge the antenna is to be placed. For good performance to be maintained this minimum size is recommended to be no less than 30mm in length. Below shows the change in performance when the ground plane size is reduced.

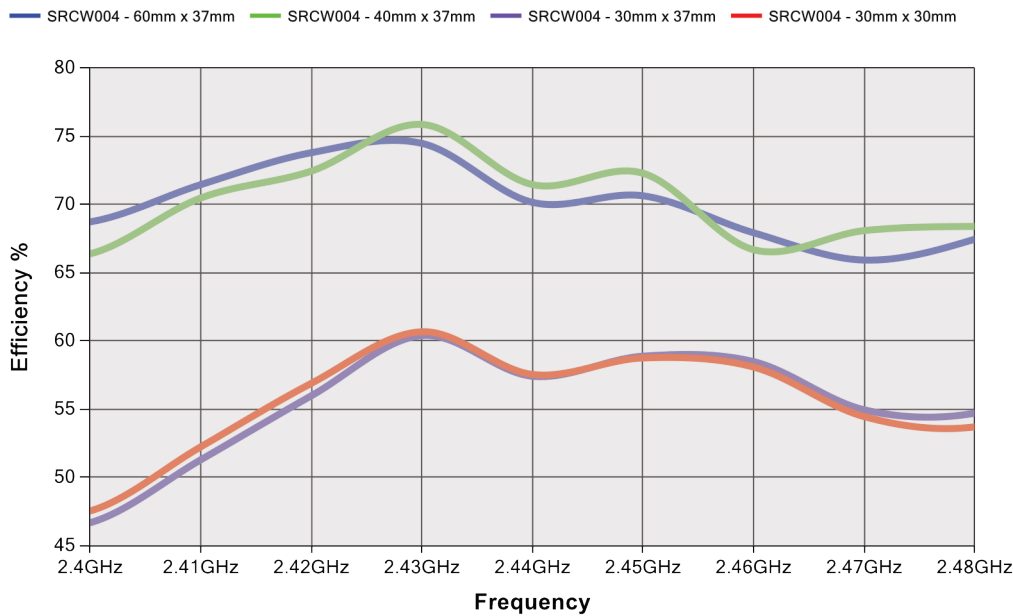
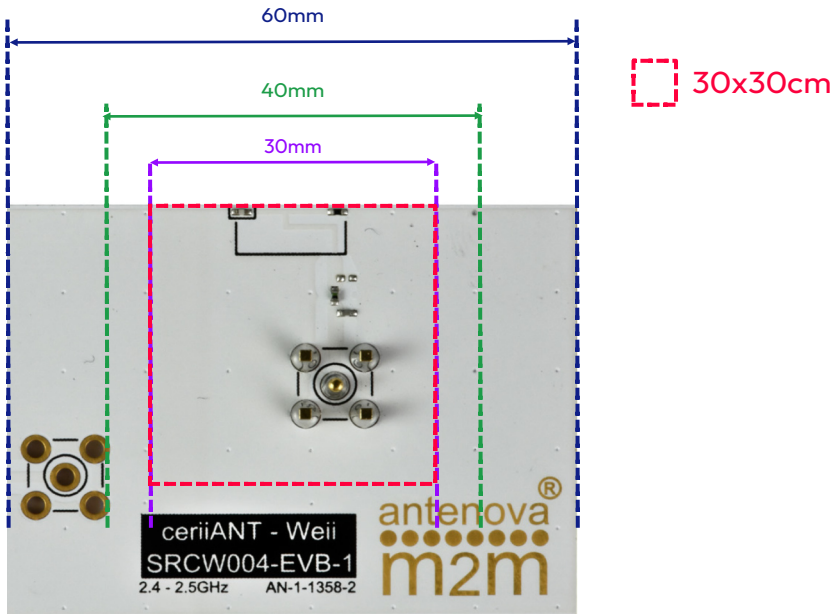

11.2. Host PCB layout

The copper tracks etched on the PCB form an integral part of the antenna, and any deviation from the advised layout shown below will result in a loss in the antenna performance. It is best that the copper track layout is imported from CAD files which are available from Antenova on request.

Please visit ask.antennova for further details.

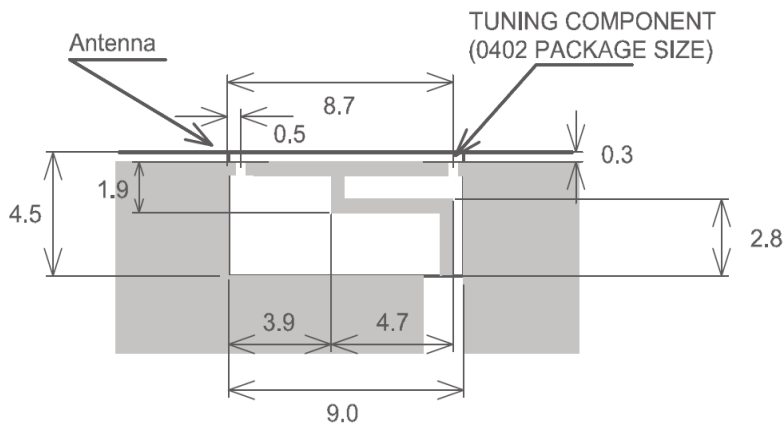

ALL TRACE WIDTHS EQUAL 0.5mm
 ANTENNA CLEARANCE AREA 9 x 4.5mm
 ANTENNA DISTANCE TO PCB EDGE = 0.3mm

 COPPER TRACE
 ALL DIMENSIONS IN mm

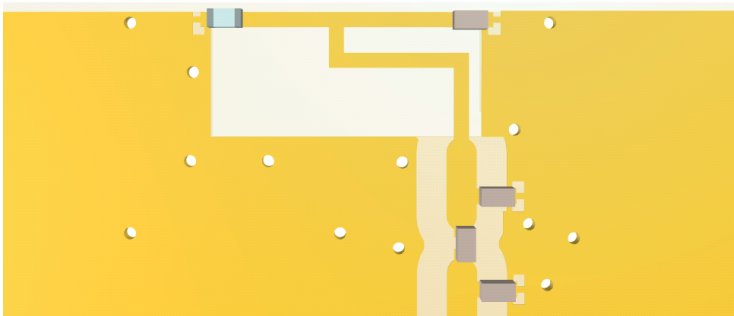

11.3. Host PCB clearance

The host PCB must be designed using the PCB footprint shown with the correct clearances. An example of the PCB layout shows the antenna footprint. Please note this clearance area is critical to the performance of the antenna and must be applied through all layers of the PCB.

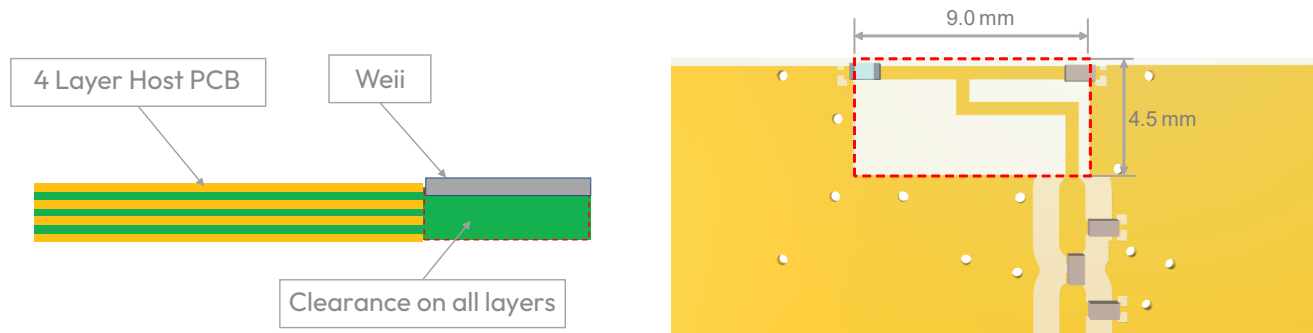

11.4. MIMO applications example

This ceramic antenna is ideal for applications requiring multiple antennas for MIMO systems. In this example two antennas are shown mounted on Antenova evaluation PCB and represents a good example when applying this antenna within a MIMO system.

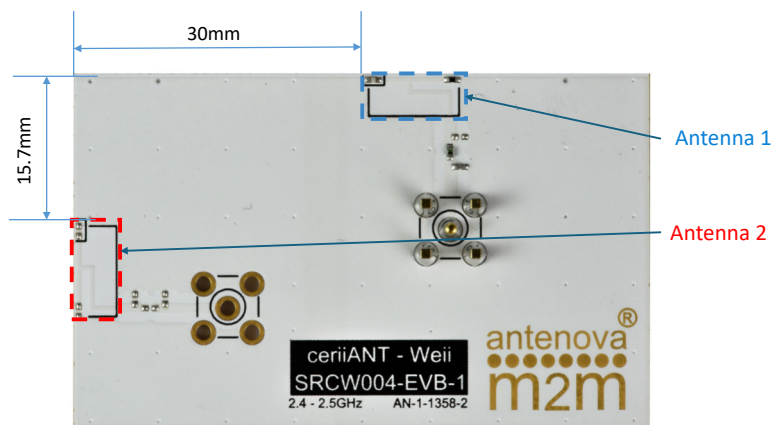

Two antennas placed perpendicular to each other at a distance of 28mm from antenna clearance edges. Both antennas were optimised and matched to the same frequency.

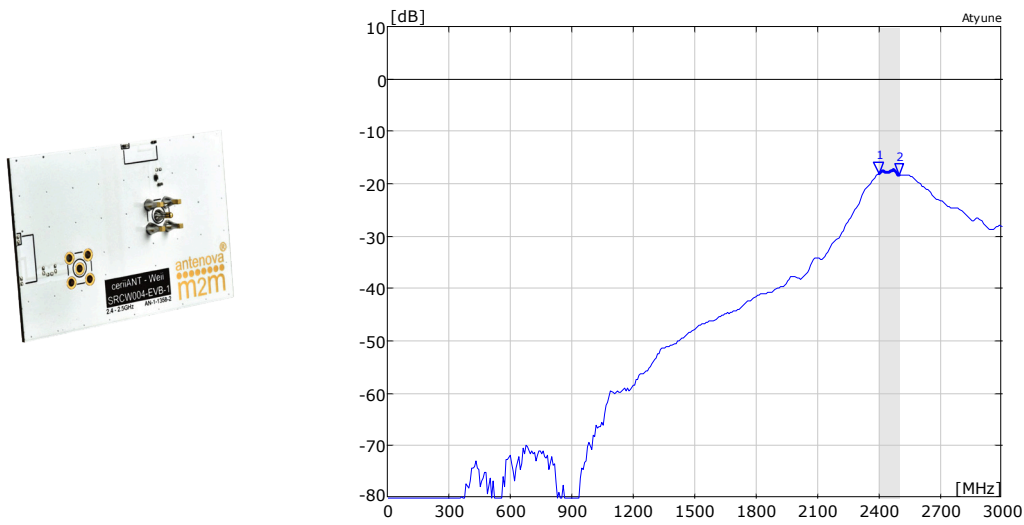

The radiation patterns for the MIMO configuration.
3D pattern at 2450MHz

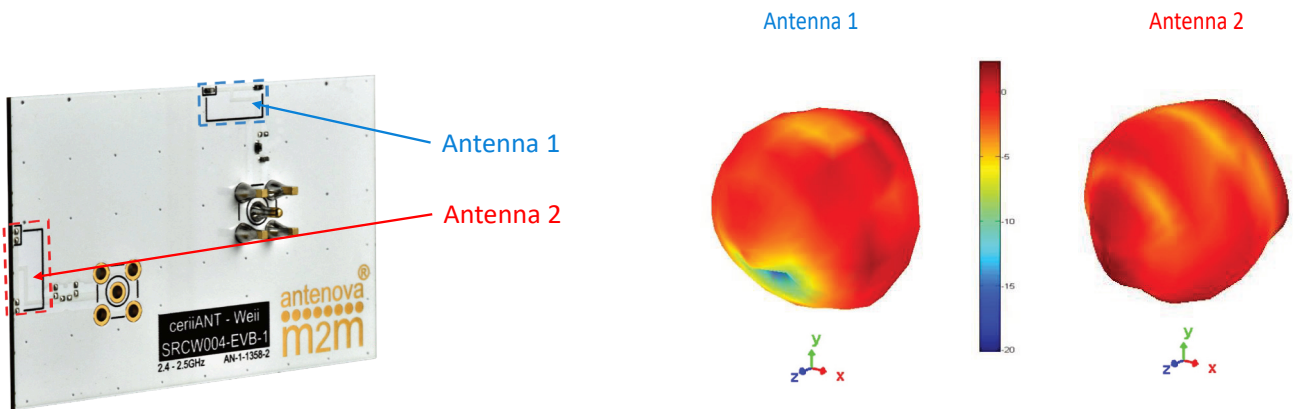

11.5. Wearable device example

Wearable devices require the use of small PCB's with limited clearance due to components and close proximity to the human body. Some guidelines to follow when designing small devices are illustrated in the example below.

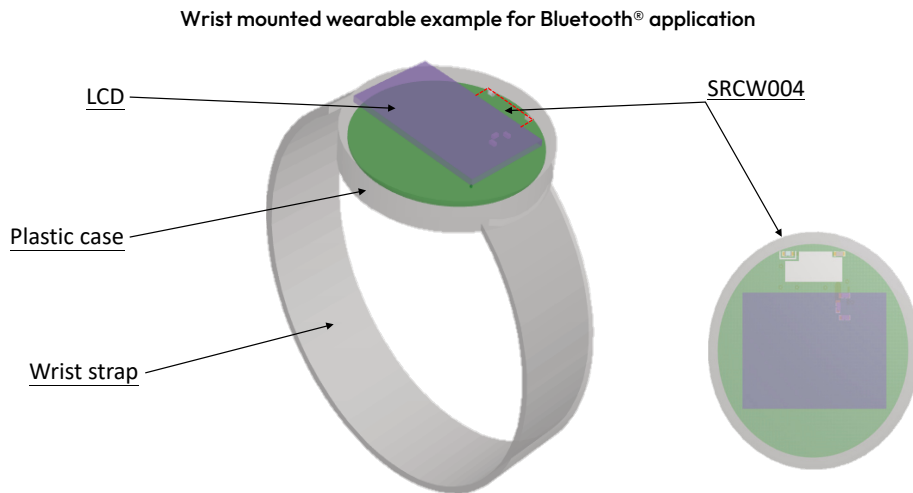

1. Antenna clearance must be maintained above and below, with exception of the human body making contact with the external case.
2. Components such as LCD or Battery to keep clear of antenna section.
3. Place antenna on longest PCB edge, in this case close to edge of the circular PCB.
4. Height from human body should be greater than 4mm to minimise losses (>4mm)
5. Outer case should not contain metal close to the antenna where possible.
Certain metalized coatings are possible where they do not conduct effectively.

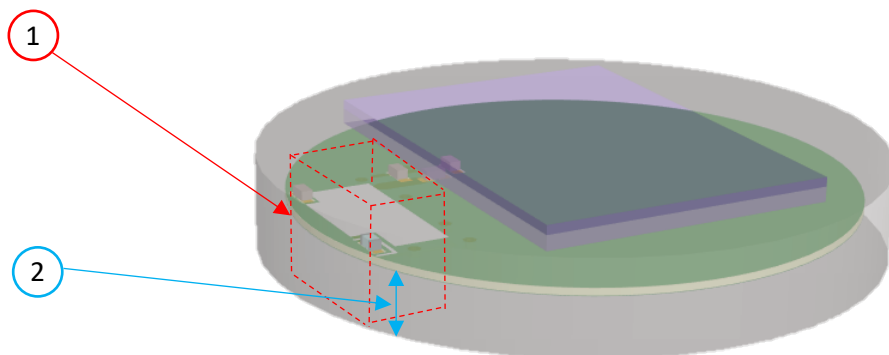

12. Reference board

A reference board is used for evaluating the antenna SRCW004 and it includes a SMA female connector. (Part number: SRCW004-EVB-1)

To order a reference board please see antenna.com

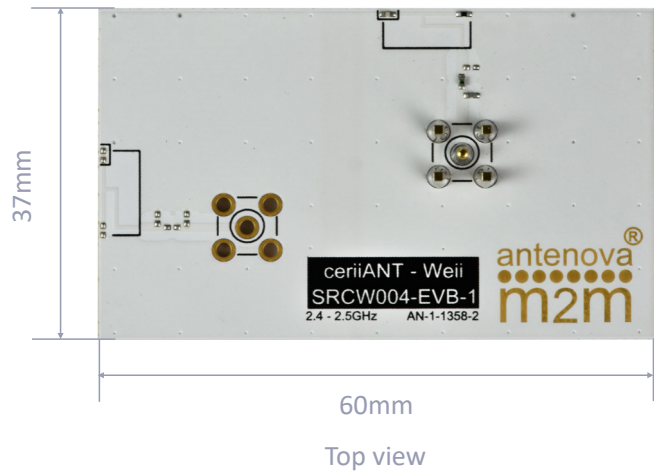

12.1. Reference board matching circuit

Designator	Type	Value	Description
R1	Resistor	0 ohm	Non-specific (0402)
C1	NA	DNP	Not Fitted
L1	Inductor	3.3nH	Murata LQG15HS series
C2	Capacitor	0.5pF	Murata GJM15 series

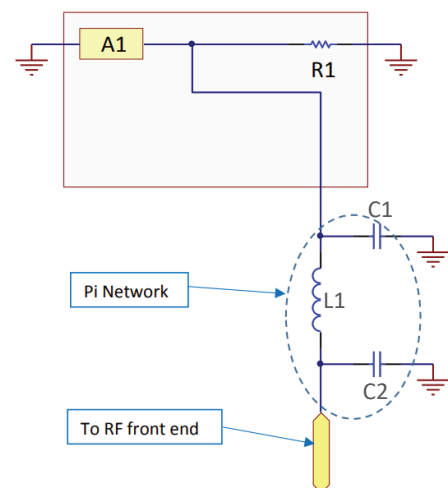

13. Soldering

This antenna is suitable for lead free soldering. The reflow profile should be adjusted to suit the device, oven and solder paste, while observing the following conditions:

- For leaded soldering, the maximum temperature should not exceed 240 °C.
- For lead free soldering, a maximum temperature of 255 °C for no more than 20 seconds is permitted.
- The antenna should not be exposed to temperatures exceeding 120 °C more than 3 times during the soldering process.

14. Hazardous material regulation conformance

The antenna has been tested to conform to RoHS and REACH requirements. A certificate of conformance is available from Antenova's website.

15. Packaging

15.1. Optimal storage conditions

Temperature	-10°C to 40°C
Humidity	Less than 75% RH
Shelf life	24 Months
Storage place	Away from corrosive gas and direct sunlight
Packaging	Reels should be stored in unopened sealed manufacturer's plastic packaging.
MSL level	1

Note: Storage of open reels of antennas is not recommended due to possible oxidization of pads on antennas. If short term storage is necessary, then it is highly recommended that the bag containing the antenna reel is re-sealed and stored in conditions as described in the table above .

The shelf life of the antenna is 2 years provided the factory seal on the package has not been broken.

15.2. Tape characteristics

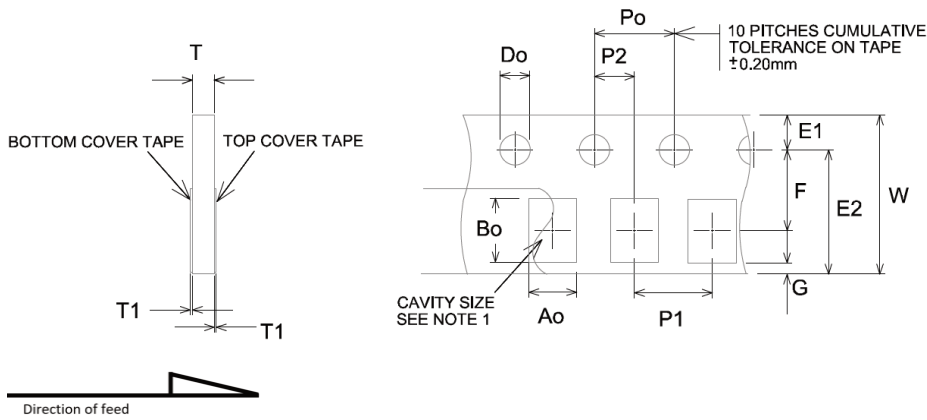

D0	E1	E2	F	G	Po
1.50 +0.1	1.75 ± 0.1	6.25 ± 0.1	3.50 ± 0.05	0.75min	4.0±0.1

P1	P2	T	T1	W	Ao & Bo
4.00±0.1	2.00±0.5	1.10 max	0.1 max	8.00±0.3	See note 1

Notes:

The cavity defined by Ao, Bo, and T shall be configured to provide sufficient clearance surrounding the antenna so that:

- a) The component does not protrude beyond either surface of the carrier tape.
- b) The component can be removed from the cavity in a vertical direction without mechanical restriction after the top cover tape has been removed.
- c) Rotation of the component is limited to 20° maximum.
- d) Lateral movement of the component is restricted to 0.5mm maximum.

15.3. Reel dimensions

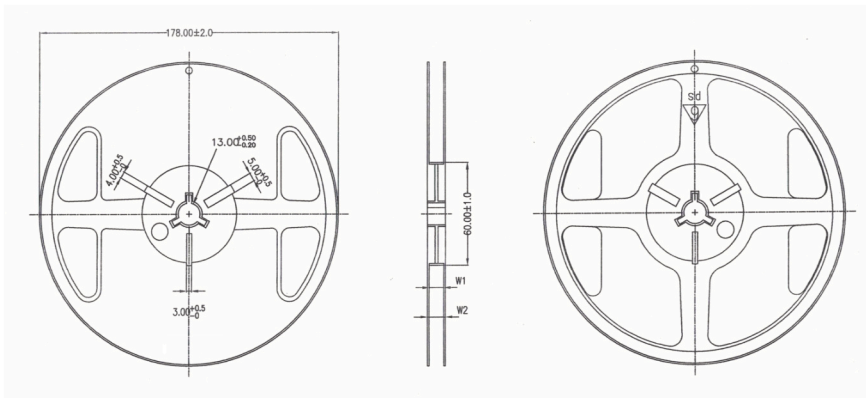

W1	W2
9.0 ± 0.5mm	11.4 ± 0.5mm

All dimensions in (mm)

Quantity	Leading space	Trailing space
10000 pcs/reel	16 blank antenna holders	24 blank antenna holders

15.4. Box dimensions

Reels are supplied in protective plastic packaging.

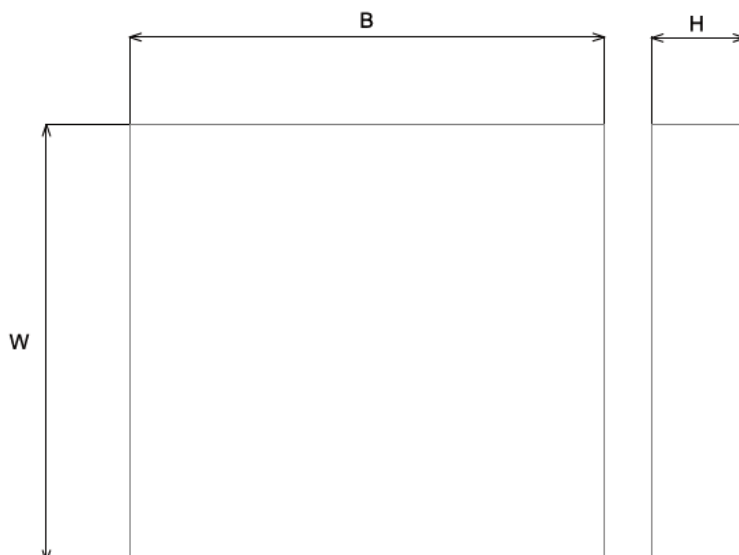

Width (W)	Breadth (B)	Height (H)
200 mm	185 mm	40 mm

15.5. Bag properties

Reels are supplied in protective plastic packaging.

15.6. Reel label information



Quality statements

Antenova’s products conform to REACH and RoHS legislation. For our statements regarding these and other quality standards, please see antenova.com.

Antenova reserves all rights to the contents of this document. Antenova gives no warranties based solely on the accuracy or completeness of the contents of this document and reserves the right to make changes to the specifications of the products described herein at any time and without notice.



Data sheet

4.04 release 27th May 2026

Antenna design, integration and test resources

Product designers – the details contained in this datasheet will help you to complete your embedded antenna design. Please follow our technical advice carefully to obtain optimum antenna performance.

We aim to support our customers to create high performance wireless products. You will find a wealth of design resources, calculators and case studies to aid your design on our website.

Antenova's design laboratories are equipped with the latest antenna design tools and test chambers. We provide antenna design, test and technical integration services to help you complete your design and obtain the required certifications.

If you cannot find the antenna you require in our product range, please contact us to discuss creating a custom antenna to meet your exact requirements.

Share knowledge with RF Experts around the world

ask.antenova is a global forum for designers and engineers working with wireless technology

[Visit Ask.Antenova](#)

Visit antenova.com

Order antenna samples and evaluation boards, and read our antenna resources

[Visit antenova.com](http://antenova.com)

Request a volume quotation for antennas:

sales@antenova.com

+ 44 (0) 23 9400 1023

Global headquarters

**Antenova Ltd, 7 The Briars,
Waterberry Drive, Waterlooville,
Hampshire, PO7 7YH**